



---

## **Installation**

This bulletin should be used by experienced personnel as a guide to the installation of the Marley M-5 vibration switch. Selection or installation of equipment should always be accompanied by competent technical assistance.

---

### **⚠ Caution**

*Before proceeding to install and wire the unit, read and thoroughly understand these instructions. The switch model number should be checked to confirm that you have the correct hazardous area rating for your application.*

### **Installation**

- 1—The sensitive axis of the vibration switch is perpendicular to the mounting base. The preferred mounting is with the sensitive axis in the horizontal plane, since most machines vibrate more in that plane. Mount the switch solidly to the frame of the machine. In most cases the switch or mounting bracket will come preinstalled.
- 2—Remove the cover and wire the switch(es) into the alarm or shutdown circuit. Do not exceed switch contact ratings listed in the specifications. Keep field wiring away from the moving part of the mechanism.
- 3—Observe all local electrical codes.
- 4—All the power must be switched off before opening of the enclosure in an explosive atmosphere.
- 5—The Vibration Switch must be electrically connected by means of a flame-proof cable gland or stopping box certified to EN 50018.
- 6—For ambient temperatures below +14°F and above +140°F use field wiring suitable for both minimum and maximum ambient temperature.
- 7—Reinstall the cover by first insuring the sealing gasket is in place and properly seated in the groove in the housing. Place the cover on the unit and install the four cover bolts. Torque the four bolts to 16 ft·lb. Caution should be used to not over-torque the bolts as this could damage the housing and compromise the seal.
- 8—The temporary conduit entry plugs are placed in the housing to provide physical protection for the threads during shipping. Once the unit is installed in the field these plugs must be replaced. These temporary plugs do not provide adequate environmental protection for the switch when installed in the field.

---

# Installation

## Vibration Switch Testing

---

### **⚠ Warning**

*The vibration switch is a safety circuit acting as a run permissive for the VFD or starter controlling the fan motor. Follow lockout / tagout procedures on the fan starting equipment.*

---

### **⚠ Caution**

*A special tool is required to adjust the setpoint—do not attempt to adjust. Adjusting the setpoint will VOID the warranty. The setpoint is factory set at 1g which is more than sufficient to allow the mechanical equipment to get up to speed without tripping the motor. The default trip setting should allow for a full voltage start and operation at all speeds.*

---

### **Note**

*During installation and testing, if a problem with either the sensitizing or desensitizing setting is suspected or you think the unit is defective, do not attempt to adjust the setpoint. Call 800-462-7539 or 281-940-1802 Field Service or 713-702-8805 Technical Assistance after hours for troubleshooting.*

To test the operation of the electrical contacts in the vibration switch please follow one of the provided procedures below. The first test procedure is the recommended procedure to use without having to remove the switch cover.

**Test 1 – Do not adjust the setpoint.** Loosen the four mounting bolts on the vibration switch support—do not remove. Either lightly tap or shake the vibration switch thus triggering the unit indicating the unit is active. Retighten the mounting bolts and reset the unit.

**Test 2 – Do not adjust setpoint.** Remove the cover to expose the inside of the switch. Using a screwdriver, toggle the trip plate to force the electrical contacts open and closed. The trip plate is bright metal and measures 1¾" x 1" and is located towards the bottom of the switch. With the adjusting pin located to the left, the normally closed contact will be closed when the right hand side of the trip plate is depressed. Check continuity at the terminal points COMMON and NORM CLOSED or at the fan controller to confirm contacts are operational. A typical control circuit uses a closed contact to allow the fan to run. An open contact means excessive vibration has occurred shutting off the starter or VFD.

---

## **Installation**

---

### **Note**

*As stated previously, adjusting the setpoint will void the warranty on this switch. If by either accident or intentionally, the setpoint is tampered with, the following instructions are provided indicating how to properly readjust the setpoint. If the proper setpoint cannot be achieved through these steps, then call for technical assistance. In order to adjust the setpoint, a special tool is required and may be furnished upon request from SPX Cooling Technologies.*

### **Turning Setpoint Adjustment Too Far Counter-Clockwise**

- If the setpoint adjustment is turned too far counter-clockwise (approximately 3-4 turns) the switch will trip and will not stay in a reset position after depressing the manual reset push-button.
- At approximately 11 turns the switch will trip and cannot be reset because the spring and adjusting rod have dislodged out of position. There is no mechanical stop position when turning counter clockwise. Repair of the internal mechanism can be accomplished in the field by removing the internal switch mechanism from the switch body. The switch mechanism is held in with three screws. Once removed the adjusting rod and spring may be put back into operating position.

### **Turning Setpoint Adjustment Too Far Clockwise**

- The adjusting rod has a nylon stop bushing preventing the rod from being over turned. Once the adjustment bottoms out, the switch is at or beyond the maximum setting and may not trip on vibration.

### **Getting The Adjustment Position Back To Normal**

- Once an adjustment is out of range and the rod and spring have not been dislodged the switch may be adjusted back to normal settings. With the switch cover removed rotate the adjusting rod clockwise until it bottoms out. Push the right hand side of the trip plate down to reset the switch. At this point the NORM CLOSED CONTACT is closed. Rotate the adjusting rod approximately two turns counter-clockwise slowly or until the trip bar moves up with a click. Then rotate the adjusting rod clockwise one full turn. If the cooling product fan start or run position trips the switch then rotate the adjusting rod clockwise in  $\frac{1}{8}$  increments until the trip holds in.

---

## ***Installation***

### **Electrical Reset and Startup Lockout**

The optional electrical reset circuit consists of an electrical solenoid in series with a thermistor. If the rated voltage is continuously applied to the reset circuit at startup, the reset solenoid energizes for a fixed time interval (approximately 30 seconds), after which time the solenoid is automatically de-energized by the thermistor. This action provides a trip lockout during machine startup roughness. The voltage must be removed from the reset circuit when the fan motor is stopped to allow the thermistor to cool off. The switch mechanism can then be reset electrically by a momentary application of the reset voltage or it can be reset manually.

---

#### **Note**

*If the fan motor is restarted immediately after a shutdown, the lockout period will be shortened because the thermistor will be hot. An increase in the ambient temperature will also shorten the lockout period.*

### **Specifications**

**Function**—Armature mechanism trips on high vibration and operates snap action switch(es).

**Frequency Range**—0 to 3600 RPM.

**Reset**—Local reset, plus optional remote reset electrical coil. See How to Order ("D").

**Start Delay**—Applying reset coil voltage at start up holds mechanism from tripping for 20-30 seconds, after which the switch is active. Requires electric reset option.

**Temperature Range**— -40°F to 160°F

**Enclosure**—High strength copper-free ( $\frac{4}{10}$  of 1% max) aluminum alloy.

**Environmental Rating**—NEMA 4, IP 65 & CE Mark (NEMA 4X Optional).

**Switch Contact(s) Rating**—15 amps, 125, or 480 VAC;  $\frac{1}{8}$  hp, 125 VAC;  $\frac{1}{4}$  hp, 250 VAC;  $\frac{1}{2}$  amp, 125 VDC;  $\frac{1}{4}$  amp, 250 VDC.

**Hazard Rating**—See How to Order ("A").

**Weight**—4.0 lb

# Information

## Schematic

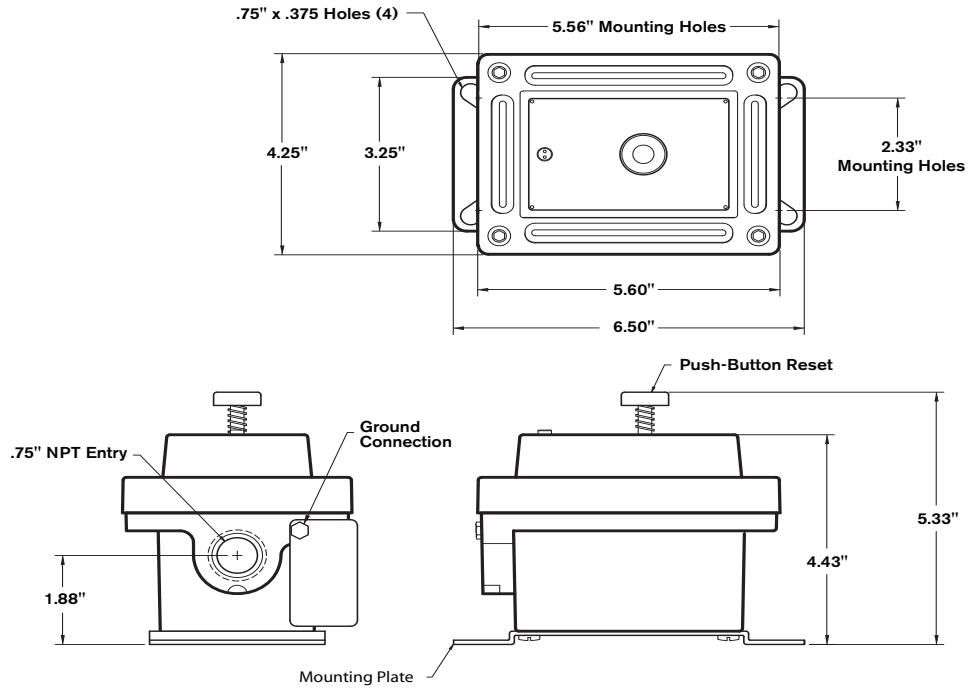

## Wiring

Dependent on switch configuration

<p>DPDT Contacts</p> <p>L (+) 7 Reset Coil N (-) 8 Reset Coil GRN ——— Case</p>	<p>SPDT Contacts</p> <p>L (+) 4 Reset Coil N (-) 5 Reset Coil GRN ——— Case</p>
<p>DPDT Contacts</p>	<p>SPDT Contacts</p>

---

## Information

### How To Order

For new or replacement vibration switches call 1-800-4Marley

**M-5**    **A**  **B**  **C**  - **D**  **E**  **F**

Example: **M-5 111-010**

**A**  **Hazard Rating**

0 = None

1 = UL, cUL Explosion Proof, Class I, Div 1, Groups C and D  
Class II, Div 1, Groups E, F and G

2 = UL, cUL Explosion Proof, Class I, Div 1, Groups B, C and D  
Class II, Div 1, Groups E, F and G

**B**  **Contacts**

1 = SPDT 2 = DPDT

**C**  **Full Scale Range**

1 = 5g 2 = 2g 3 = 10g

**D**  **Reset Coil and Startup Delay**

0 = None 1 = 115VAC 2 = 230VAC 3 = 24VDC 4 = 115VDC

**E**  **Wiring Entry/Mounting Plate** (retro fit)

1 = 3/4" NPT 6 = M20 x 1.5

**F**  **Environmental Rating**

0 (or blank) = NEMA 4, IP65 1 = NEMA 4X, IP65

Tested for compliance with the applicable EC Electromagnetic Compatibility requirements



**note** When Option **C** = 2, Option **D** cannot = 3 for operation in the horizontal axis.

When Option **A** = 1 or **A** = 2, Option **E** cannot = 6

---

## ***Information***

### **Environmental**

---

#### **Note**

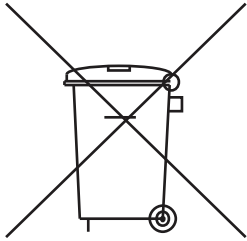

This electronic equipment was manufactured according to high quality standards to ensure safe and reliable operation when used as intended. Due to its nature, this equipment may contain small quantities of substances known to be hazardous to the environment or to human health if released into the environment. For this reason, Waste Electrical and Electronic Equipment (commonly known as WEEE) should never be disposed of in the public waste stream. The “Crossed-Out Waste Bin” label affixed to this product is a reminder to dispose of this product in accordance with local WEEE regulations. If you have questions about the disposal process, please contact SPX Cooling Technologies customer service.

**SPX**<sup>®</sup>

**COOLING TECHNOLOGIES**

7401 WEST 129 STREET | OVERLAND PARK, KANSAS 66213 UNITED STATES | 913 664 7400 | [spxcooling@spx.com](mailto:spxcooling@spx.com) | [spxcooling.com](http://spxcooling.com)

In the interest of technological progress, all products are subject to design and/or material change without notice.  
©2010 SPX Cooling Technologies, Inc. | Printed in USA

M2010-1241